



MOTORIZED LARGE TV CARTS/STAND

ANRTLE60100T

ANRTLE60100

ANFSE60100TWM

Made for office, education and hospitality use, the ANRTLE60100T Motorized Height Adjustable TV Carts and Stand are a versatile solution for those seeking mobile or shared viewing of TVs for presentations, video conferencing and more. Powerful dual motor design provides ample ability to raise and lower even the heaviest TVs (120kg / 264.6 lbs). The ANRTLE60100T Series provide the perfect solution to gather, display and share information for today's changing needs.

For more information contact:

Anchor AV, P.O. Box 121071, Dubai, U.A.E.

Tel: +971 4 3706522, Email: enquiry@anchorav.com

Copyright © 2020 Anchor AV. ANCHOR **PRO** is the registered trademark of Anchor AV Accessories. Specifications and terms are subject to change without prior notice.

Motorized Large TV Carts/Stand

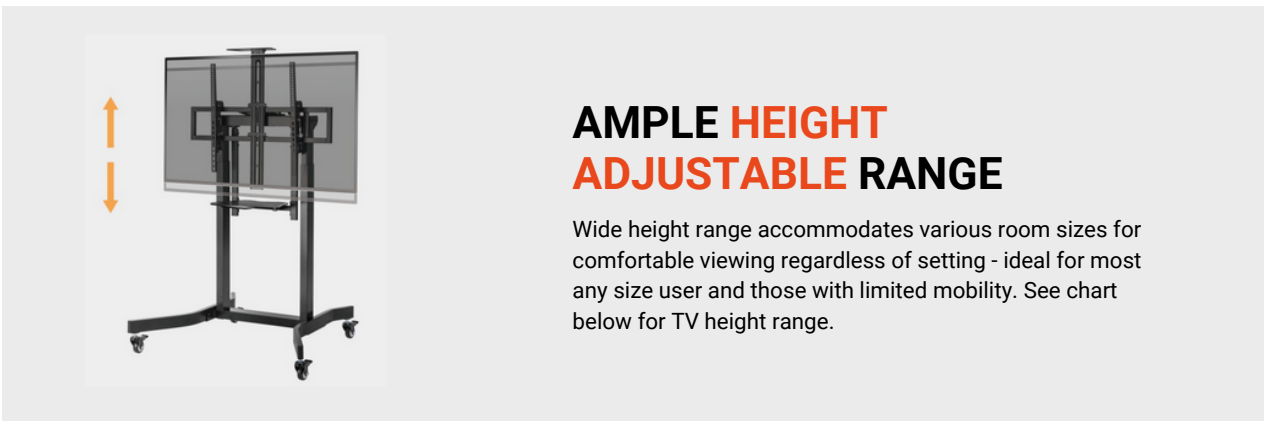

Universal VESA Mount

supports large TVs from 55"-100"



Powerful Lifting Motor

smooth and quiet movement - even with the heaviest TVs



Locking Casters

effortless and smooth movement without scuffing floors that lock firmly in place



Available with Storage Shelf and Camera Mount

Ideal for holding materials or small equipment (5kg/11 lbs.) along with camera perch for tele-conferencing use (TTL14-68TW Only)



Robust Construction

Laboratory tested to 4 times weight capacity for confident long term use.

Motorized Large TV Carts/Stand

ANTRTLE60100T

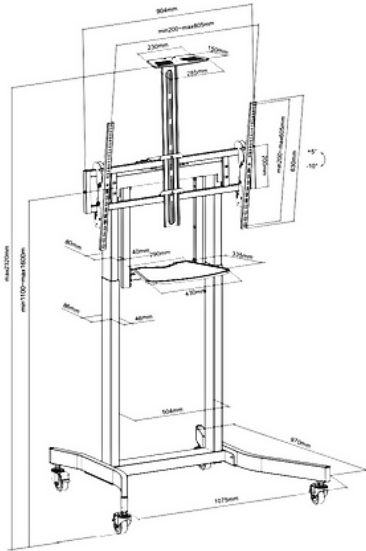

ANTRTLE60100

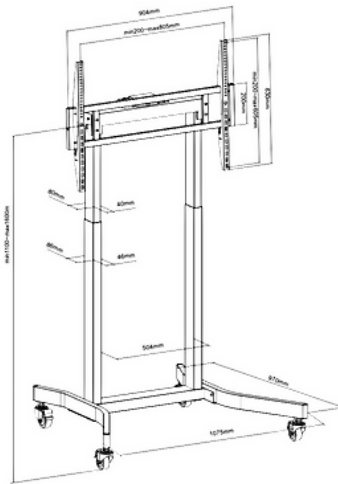

ANFSE60100TWM

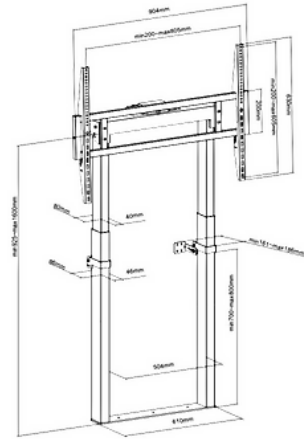

Item No.	ANTRTLE60100T	ANTRTLE60100	ANFSE60100TWM
Dimensions	1075x970x1445-2320mm (42.3"x38.2"x56.9"-91.3")	1075x970x1425-1925mm (42.3"x38.2"x56.1"-75.8")	904x250x1250-1925mm (35.6"x9.8"x49.2"-75.8")
TV Height Range	1100-1600mm (43.3"-63")	1100-1600mm (43.3"-63")	925-1600mm (36.4"-63")
Weight Capacity	120kg (264lbs)	120kg (264lbs)	120kg (264lbs)
Compatible Screen Size	55"-100"	55"-100"	55"-100"
VESA	200x200, 300x200, 300x300, 350x350, 400x300, 400x200, 400x400, 600x200, 600x400, 800x400, 800x600	200x200, 300x200, 300x300, 350x350, 400x300, 400x200, 400x400, 600x200, 600x400, 800x400, 800x600	200x200, 300x200, 300x300, 350x350, 400x300, 400x200, 400x400, 600x200, 600x400, 800x400, 800x600
Materials	Aluminum, Steel & Plastic	Aluminum, Steel & Plastic	Aluminum, Steel & Plastic
Tilt	+5°~-10°	No	No
Storage Shelf	Yes	No	No
Camera Mount	Yes	No	No
Colors	<input checked="" type="checkbox"/> Black <input type="checkbox"/> White		

For more information contact:

Anchor AV, P.O. Box 121071, Dubai, U.A.E.

Tel: +971 4 3706522, Email: enquiry@anchorav.com

Copyright © 2020 Anchor AV. ANCHOR PRO is the registered trademark of Anchor AV Accessories. Specifications and terms are subject to change without prior notice.